

SECOND STARTER WIRE

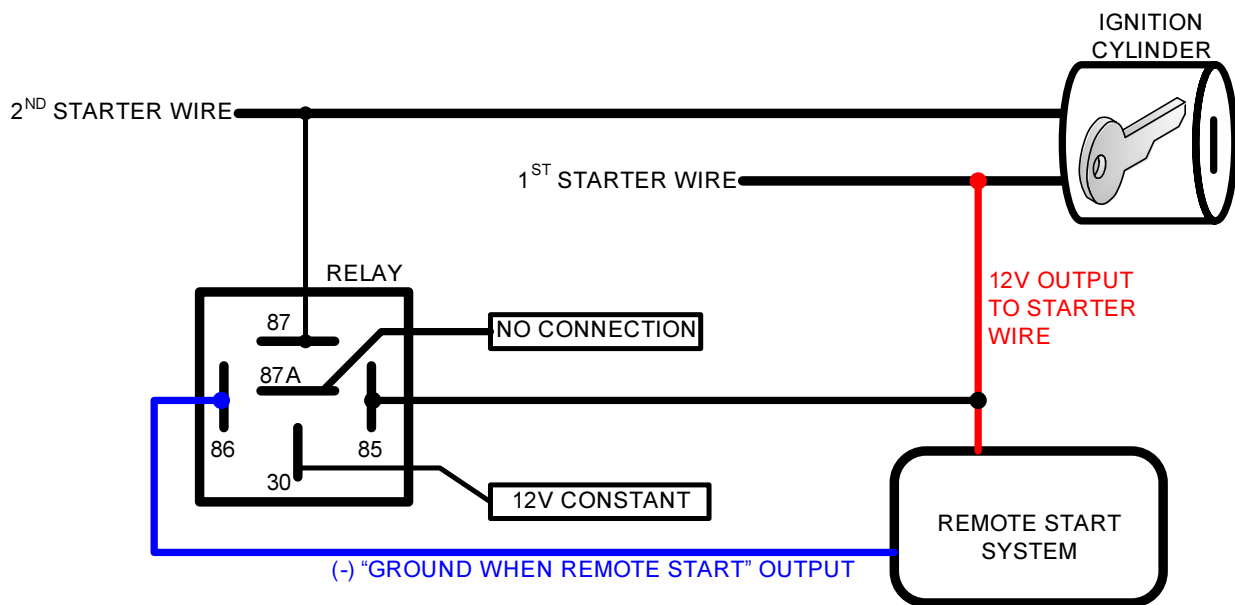

NOTE:

Some vehicles (Nissans, Infinitis, as well as some European vehicles) have more than one starter wire. This second starter wire is a “cold start” wire. This second starter wire is needed for remote start installations only. This second starter wire must be energized for the remote start process in order for the vehicle to start properly. If the system only has one (+) starter output, use a relay for each additional starter wire that must be energized and wire as shown:



PIN	CONNECTION
85	SPLICE ONTO (+) OUTPUT GOING TO 1 ST STARTER WIRE
86	CONNECT TO (-) OUTPUT FROM REMOTE START WHEN REMOTE START IS ACTIVATED
87	CONNECT TO (+) SECOND STARTER WIRE
87A	NO CONNECTION
30	CONNECT TO 12V CONSTANT (25 AMP CAPABLE)

Remote starter and security installations should be attempted by experienced security installers only. Information contained is accurate to the best of our knowledge and experience. Information contained is without any representation of warranty. It is the installer's responsibility to test and confirm all circuits with a digital multi-meter. Proper installation remains the responsibility of the installer. CarInstallExperts.com assumes no liability or responsibility resulting from an improper installation, even in reliance with the information contained in this guide.